

# Heatcraft Coil Certified Drawing

Drain Pan CP-2015-C



Customer \_\_\_\_\_ Customer P.O. Number \_\_\_\_\_

Job \_\_\_\_\_

Written by \_\_\_\_\_ Date \_\_\_\_\_

Approved by \_\_\_\_\_ Date \_\_\_\_\_

#	TAG	QTY	CONN SIZE	MODEL NUMBER (Optional)					
				TYPE	FPI	ROWS	FIN	FH (IN)	FL (IN)
1									
2									
3									
4									

MATERIALS OF CONSTRUCTION			
#	STANDARD MATERIALS OF CONSTRUCTION	OPTIONAL MATERIALS OF CONSTRUCTION	
1	16 Gauge 304L Stainless Steel	<input type="checkbox"/> Stainless Steel 316L	<input type="checkbox"/> 16 GA Galvanized
2	16 Gauge 304L Stainless Steel	<input type="checkbox"/> Stainless Steel 316L	<input type="checkbox"/> 16 GA Galvanized
3	16 Gauge 304L Stainless Steel	<input type="checkbox"/> Stainless Steel 316L	<input type="checkbox"/> 16 GA Galvanized
4	16 Gauge 304L Stainless Steel	<input type="checkbox"/> Stainless Steel 316L	<input type="checkbox"/> 16 GA Galvanized

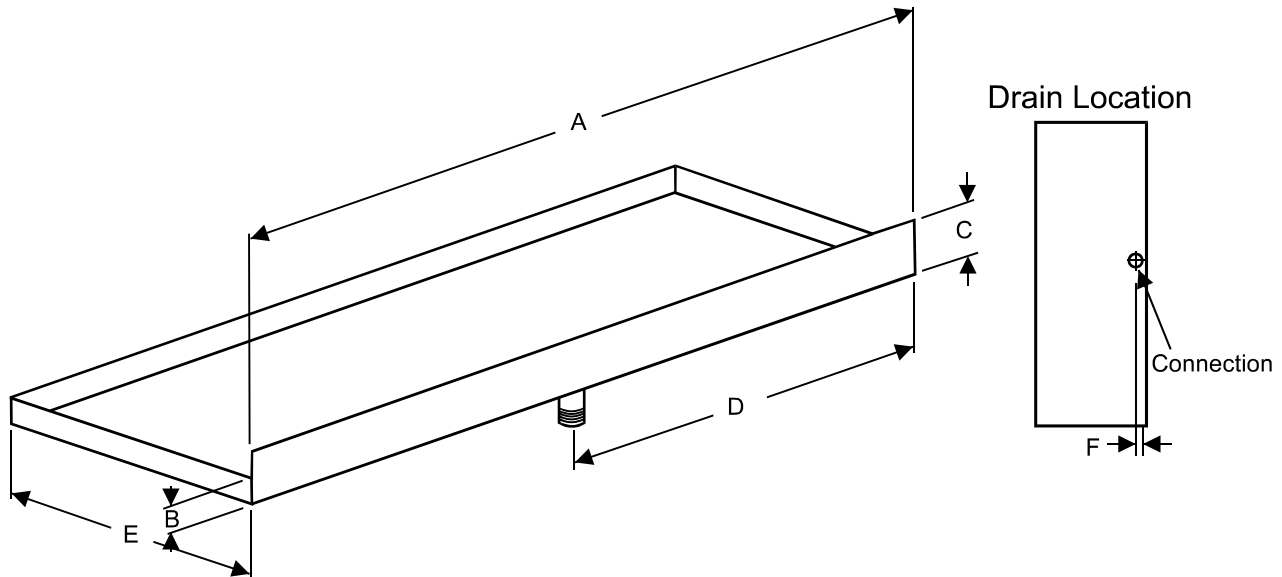

#	DIMENSIONAL DATA					
	A	B	C	D	E	F <sup>2</sup>
1						
2						
3						
4						

NOTES :

**GENERAL NOTES**

1. Drain is 1.00" MPT 304L Stainless Steel unless otherwise noted. The length of the pipe is 1.50+
2. F Dim is the distance from the front edge of the pan to the center of the drain outlet.